

FCM2630-C01 - Pre-calibrated Module for Refrigerant Gases R-32

Features:

- * Factory calibrated
- * Temperature compensation circuit
- * Resistant to interference gases
- * Analog output
- * Meets IEC60335-2-40 and JRA4068 requirements

Applications:

- * Refrigerant gas leak detection in air conditioning/refrigeration systems

FCM2630-C01 is an embedded type module using the semiconductor gas sensor TGS2630 which is optimized to detect A2L refrigerant gas R-32.

This module enables users to easily build a reliable gas leakage detection system by eliminating electronic circuit design for temperature compensation and the calibration process. In addition, a connector allows easy replacement of the gas sensor module for periodic maintenance.

The TGS2630 gas sensor has a built-in filter to reduce the influence of alcohol and other interference gases, resulting in high selectivity to R-32. For more detailed information on the gas sensor, including sensitivity characteristics, see *TGS2630 Product Information*.

FCM2630-C01 is capable of satisfying the IEC60335-2-40 Edition 6.0 Annex LL and the JRA4068:2021 (Performance 3) standards. The applicable standards are both limited to refrigerant gas type R-32.



Circuit Diagram

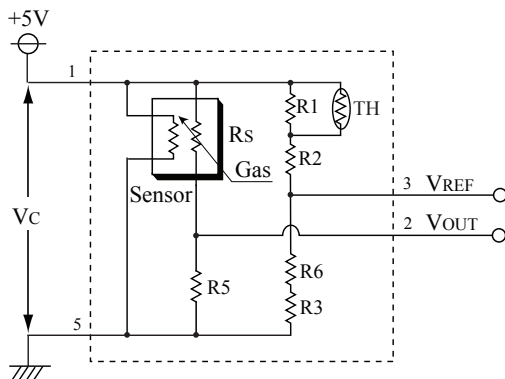

Vc: Circuit voltage
 VOUT: Output voltage
 VREF: Reference voltage

Pin Connections

Pin No.	Name	Description
1	Vc	Circuit voltage
2	VOUT	Output voltage
3	VREF	Reference voltage
4	-	-
5	GND	Common ground

Connector model: S05B-PASK-2 (made by JST)
 Recommended receptacle for connector: PAP-05V-S (made by JST)

Specifications

Model No.		FCM2630-C01
Gas sensor		TGS2630
Target gases		Refrigerant gas R-32
Circuit voltage	V _c	5.0±0.2V DC
Output voltage	V _{OUT}	3.50V typical in 5000ppm R-32 Malfunction condition: V _{OUT} < 0.05V or V _{OUT} > 4.95V (V _c = 5.00V)
Reference voltage	V _{REF}	3.50±0.10V at 20°C Malfunction condition: V _{REF} < 2.50V or V _{REF} > 3.70V (V _c = 5.00V)
Initial alarm accuracy		2800~7000ppm R-32 (under standard test conditions) Alarm state: V _{OUT} ≥ V _{REF} Normal state: V _{OUT} < V _{REF}
Warm-up time		≤60 seconds (time before V _{OUT} < V _{REF} after power is turned on in a clean atmosphere)
Operating conditions		-10°~+50°C, 20~95%RH (avoid condensation)
Power consumption		approx. 0.3W
Weight		approx. 4g
Dimensions		25 x 25 x 16mm
Standard test conditions	Test gas conditions	20°±2°C, 65±5%RH
	Circuit conditions	V _c = 5.00±0.05V DC
	Conditioning period prior to test	≥1 day

NOTE 1:

Sensor module performance may be affected if exposed to a high concentration of gas during an operating or storage period. Replace the gas sensor module if it is exposed to gas equivalent to 10,000ppm or more of R-32.

NOTE 2:

If the internal temperature near the gas sensor module becomes higher than the external ambient temperature by 10°C or more due to heat generated by electronic components in a device into which this gas sensor module is incorporated, the set alarm threshold may drift. Please consult with Figaro if there is difficulty in designing a device so as to keep the temperature rise inside the device within 10°C.

Structure and Dimensions

Top view

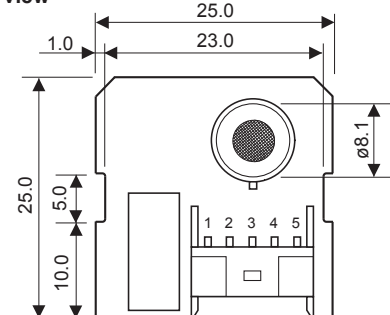

Side view

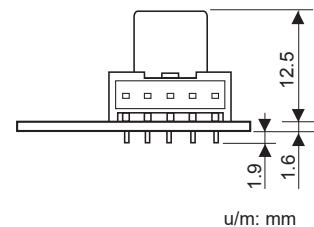

u/m: mm

All sensor characteristics shown in this brochure represent typical characteristics. Actual characteristics vary from sensor to sensor. The only characteristics warranted are those in the Specification table above.

Before purchasing this product, please read the Warranty Statements shown in our webpage by scanning this QR code.



https://www.figaro.co.jp/en/pdf/Limited_Warranty_en.pdf

FIGARO ENGINEERING INC.
1-5-11 Senba-nishi
Mino, Osaka 562-8505 JAPAN
Phone: (81)-727-28-2045
URL: www.figaro.co.jp/en/